

## VINYLOESTER POOL CARD – DESCRIPTION

### 1. TECHNICAL DRAWING

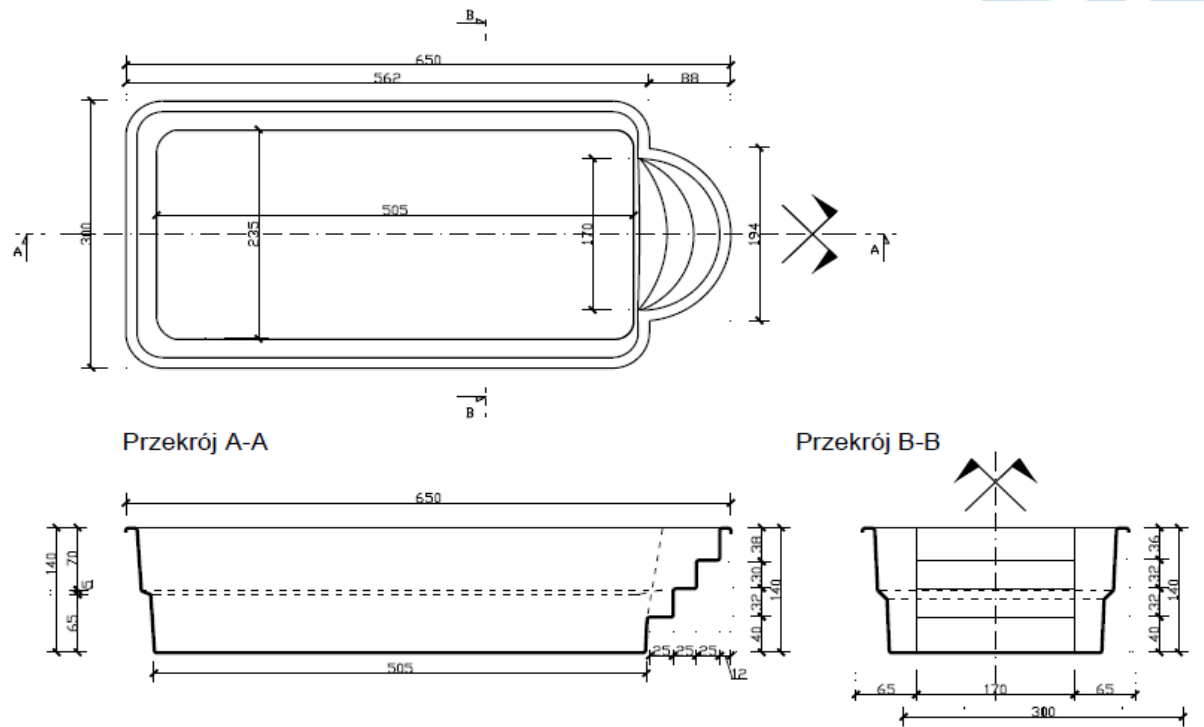

2.	<b>PRODUCT NAME</b>	Vinyloester pool Imperial I PREMIUM
3.	<b>PRODUCT CARD (size , shape, volume, weight, color )</b>	<ul style="list-style-type: none"> <li>• dimensions of the pool: 6,50 m x 3,00 m x 1,40 m</li> <li>• weight +/- 350 kg</li> <li>• rectangular shape, stairs in semicircle with non-slip surface placed on the narrower wall</li> <li>• volume +/- 20 m<sup>3</sup></li> <li>• standard colours: light blue / white – colour may slightly vary from the sample book due to lot</li> <li>• dimensions may vary +/- 3%</li> <li>• any changes to the pool construction are unacceptable</li> </ul>
4.	<b>MATERIAL (type)</b>	<u>Multi-layer construction</u> : gelcoat, anti osmosis layer, vinyloester resin + fiberglass, construction resin + fabric, reinforcements, top coat, PUR foam
5.	<b>MAXIMAL WATER TEMPERATURE</b>	27°C

6.	<b>PRODUCT'S INSULATION</b>	PUR foam ca. 1,5 cm 1 cm = 5 cm styrofoam
7.	<b>GUARANTEE</b>	Guarantee includes basins' tightness for a period of 15 years. Colour is covered by a warranty for a period of 24 months.
8.	<b>MAINTENANCE</b>	<ul style="list-style-type: none"> <li>● Pool walls cleaning: use devoted materials with dedicated pool cleaning accessories.</li> <li>● We recommend taking care of the top layer of the pool (gelcoat) through its annual impregnation with the impregnate TR-510.</li> </ul>
9.	<b>ADVISED WATER PARAMETERS</b>	<ul style="list-style-type: none"> <li>● Recommended value of pH (7,0 do 7,4),</li> <li>● Amount of chlorine 0,3 - 0,6 mg / l</li> <li>● Do not exceed the recommended values of chemical agents. Check the values on the original packages.</li> <li>● Keeping the hardness of water in recommended value up to 18 ° N,</li> <li>● Chemical agents dosing according to specifications given on its packages and results reached on the pH tester and chlorine! It is unacceptable to allow direct use of erosive substances, including chlorine on the pool walls.</li> <li>● Filtrate the water 3-4 times a day to keep it clean.</li> </ul>
10	<b>WINTER TIME</b>	<p>Pool preparation for winter:</p> <ul style="list-style-type: none"> <li>● pH regulation</li> <li>● disinfection with chlorine shock</li> <li>● filtrate water</li> <li>● add the agent - algacide so called Winterkonserwant - Preservative liquid for winter with sustained action</li> <li>● turn the pump with omission of the filter (the position of the valve: recirculate) to mix very well the agent with water</li> <li>● valve on recirculation</li> <li>● leave approx. ½ water volume in the pool, about 15-20 cm below the inflow nozzles and other protruding elements such as lamps, etc.</li> <li>● drain water from the filtration system, heat pump and other pool equipment. To remove water residing in pipes - pump the air</li> <li>● any pump should be kept in a room with temperature above zero</li> </ul>

		<ul style="list-style-type: none"><li>● thoroughly clean the pool walls, so that nothing is left on them till spring- otherwise cleaning will be more tedious</li><li>● throw into the water a few floating objects, which will absorb the force generated by the ice</li><li>● cover the pool with additional winter cover, protecting from leaves and other dirt</li></ul>
--	--	--